

STORMMASTER ***ESE Air Terminal***

COMPLIES
NF C 17-102 (2011)
STANDARD

LIGHTNING PROTECTION INTERNATIONAL PTY LTD

LPI[®]



The LPI story

Lightning Protection International Pty Ltd (LPI) is a fully Australian owned manufacturer and supplier of direct strike lightning protection, transient voltage surge suppression, and earthing / grounding solutions.

For many years, LPI have been providing specialist lightning protection advice to customers in some of the most lightning prone areas of the world. Our personnel have extensive experience in risk management, system design, training, installation, certification, and commissioning of systems in a wide variety of industry groups.

LPI maintains a third party Quality Management System to AS/NZS ISO 9001:2008.

LPI's range of products and services are exported from its head office and research facility (in Tasmania, Australia) and via regional offices worldwide.

The company has been recognised within Australia for its outstanding export successes and has been awarded several prestigious export awards.



Approvals:

IEEE



IEC

Active in Industry

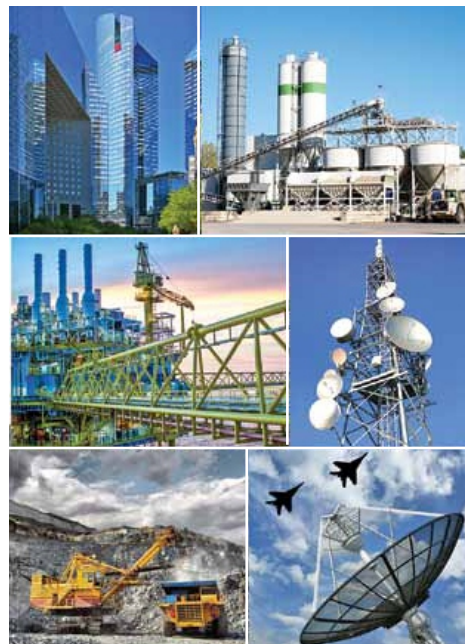

LPI's 4-Step Approach to Lightning Protection

It is the strategic aim of our company to be able to provide a complete packaged solution. LPI has identified 4 key steps when considering the complete approach to lightning protection, ask for our LPI 4 Step approach to lightning protection.

Our system design approach includes:

- 1 Definition and provision of area protection
- 2 Creation of a bonded earthing system
- 3 Protection of mains power lines
- 4 Protection of signal, data and communication lines



LPI STORMASTER ESE AIR TERMINAL

LPI's Stormaster ESE

The LPI Stormaster (Early Streamer Emission) range of terminals provides a safe and efficient system for the protection of your facility from direct lightning strikes. The LPI Stormaster ESE terminal captures the lightning energy at a **preferred point**.

How does the LPI Stormaster ESE Terminal work?

The Stormaster ESE air terminal uses the naturally occurring electrical field to complete the timely release of an upward streamer. This process provides for a safe and efficient method of controlling dangerous lightning energy at a preferred point.

As a thunderstorm gathers overhead, the ambient electrical field surrounding the Stormaster ESE begins to rise in voltage. Upon the approach of a downward leader towards the protected area, there is a rapid increase in the electric field which initiates the triggering of an upward streamer from the Stormaster ESE terminal. The early initiation allows for a larger or enhanced area of protection to be provided by the Stormaster ESE in comparison to a conventional rod, in accordance with NF C 17-102 (2011).

With the release of the upward streamer from the finial tip earlier than other competing structural points, the Stormaster ESE terminal becomes a preferred point for the capture of the lightning discharge within the protected area.

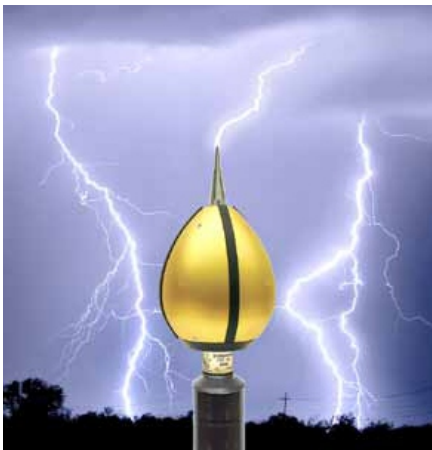

The Stormaster ESE range

LPI Early Streamer Emission (ESE) air terminals in both **Anodised Aluminium** and **Stainless Steel**.

Ordering Code:

STORMASTER ESE **-XX-YY-ZZ**

XX: Available in **15, 30, 50** and **60**

YY: Blank for Gold (anodised aluminium) model, **SS** for stainless steel model

ZZ: Blank for standard model (to FRP Mast), **GI** for 2 inch BSP GI pipe adaptor

Certified Performance

As one of the leading companies in the field of lightning protection, LPI has invested heavily in field and laboratory testing as part of its on-going commitment to research and development.

Throughout the product development of the Stormaster ESE the proto-type models were subjected to intense testing under high voltage conditions. Following further refinements the Stormaster terminals were subjected to final testing by an independently accredited test laboratory which completed testing in full compliance with the **French National Standard NF C 17-102 (2011)**. The final testing of Stormaster ESE terminals showed effective performance as defined in this Standard.

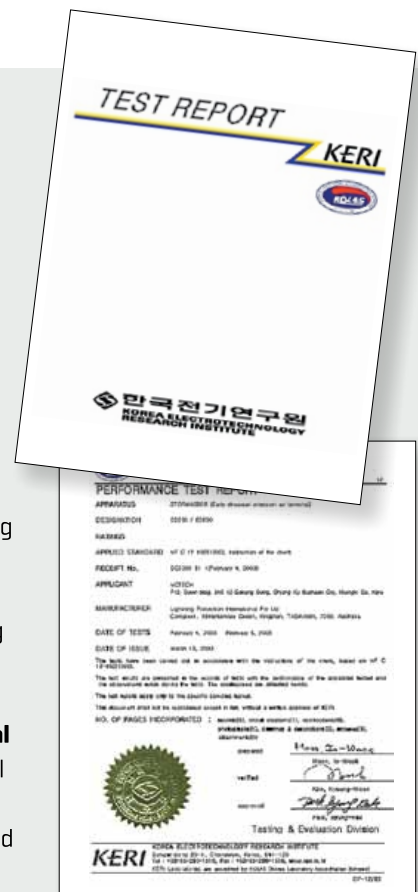

LPI STORMASTER ESE AIR TERMINAL

Downconductors

NF C 17-102 [2011] requires the installation of two downconductors for each installed ESE air terminal, with one downconductor permitted to use electrically continuous natural components of the structure.

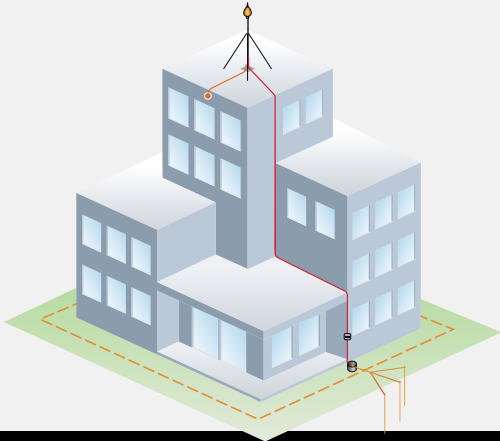

LPI offers a selection of downconductors and fixing accessories:

High Voltage Shielded Cable (HVSC)



Flat tapes - Bare, Tinned & PVC Covered



PVC Coated and bare stranded copper cable



Downconductor Fixings and Connectors



Lightning Strike Recorder (LSR)



LPI have developed a LSR which is designed for easy mounting on a downconductor to effectively count the number of lightning strikes captured by the Stormaster ESE Terminal.

Lightning Protection Earths

The installation of a radial earthing arrangement is recommended for each lightning protection earth, the radial earthing configuration provides an effective means for the safe dissipation of the lightning energy into the ground mass. All individual lightning earths should be bonded together in a ring earth arrangement to minimise ground loops and potential differences under transient conditions. Compliance to NF C 17-102 [2011] requires an earth DC resistance reading of less than 10 ohms for the lightning earths.

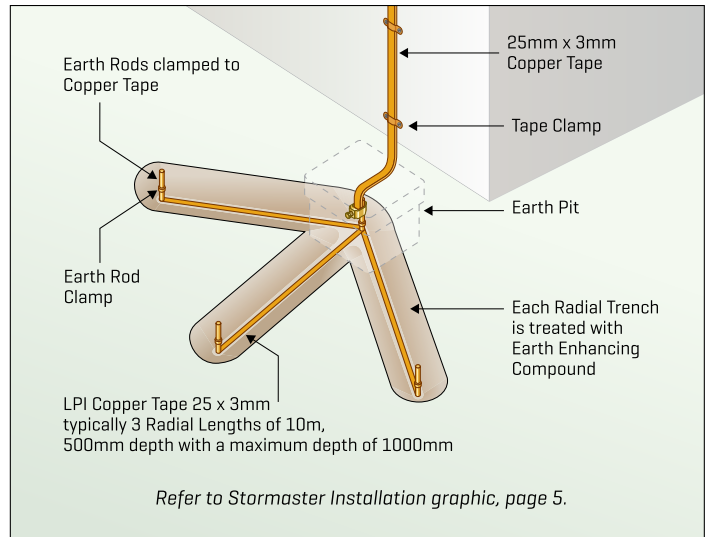

Key components of a lightning earth include:

- **Earth Rods -** Copperbonded [threaded or unthreaded], Solid Copper or Stainless Steel

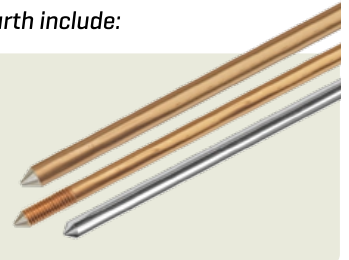

- **Earth Enhancing Compounds** to assist in lowering soil resistance



- **Mechanical Clamps and Earth Pits**

- A EPIT-C
- B EPIT-D
- C EPIT-P

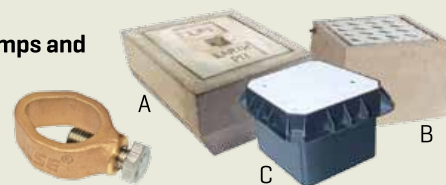

- **Earthing Conductor -** Use of flat copper tape is recommended as it provides greater surface contact with the soil mass as opposed to circular or stranded copper conductors



LPI STORMASTER ESE AIR TERMINAL

Protection Performance

The protection radius (R_p) of a Stormaster ESE terminal is calculated using the following formula as defined in NF C 17-102 [September 2011], namely:

$$R_p(h) = \sqrt{2rh - h^2 + \Delta[2r + \Delta]} \text{ for } h \geq 5 \text{ m}$$

and

$$R_p = h \times R_{p5} / 5 \text{ for } 2 \leq h < 5 \text{ m}$$

where h = Stormaster height relative to the area being protected (m)

R_{p5} = value of R_p from Eqn. [1] when $h = 5$ m

r = 20 m for protection level I (Very High protection)
 30 m for protection level II (High protection)
 45 m for protection level III (Medium protection)
 60 m for protection level IV (Standard protection)

and Δ = Stormaster height advantage according to the Stormaster model installed:

- Choices:
- Stormaster ESE 15: $\Delta = 15$ m
 - Stormaster ESE 30: $\Delta = 30$ m
 - Stormaster ESE 50: $\Delta = 50$ m
 - Stormaster ESE 60: $\Delta = 60$ m

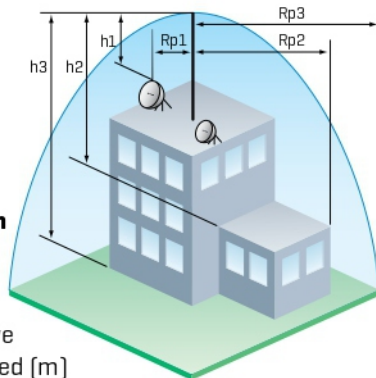

Stormaster Installation

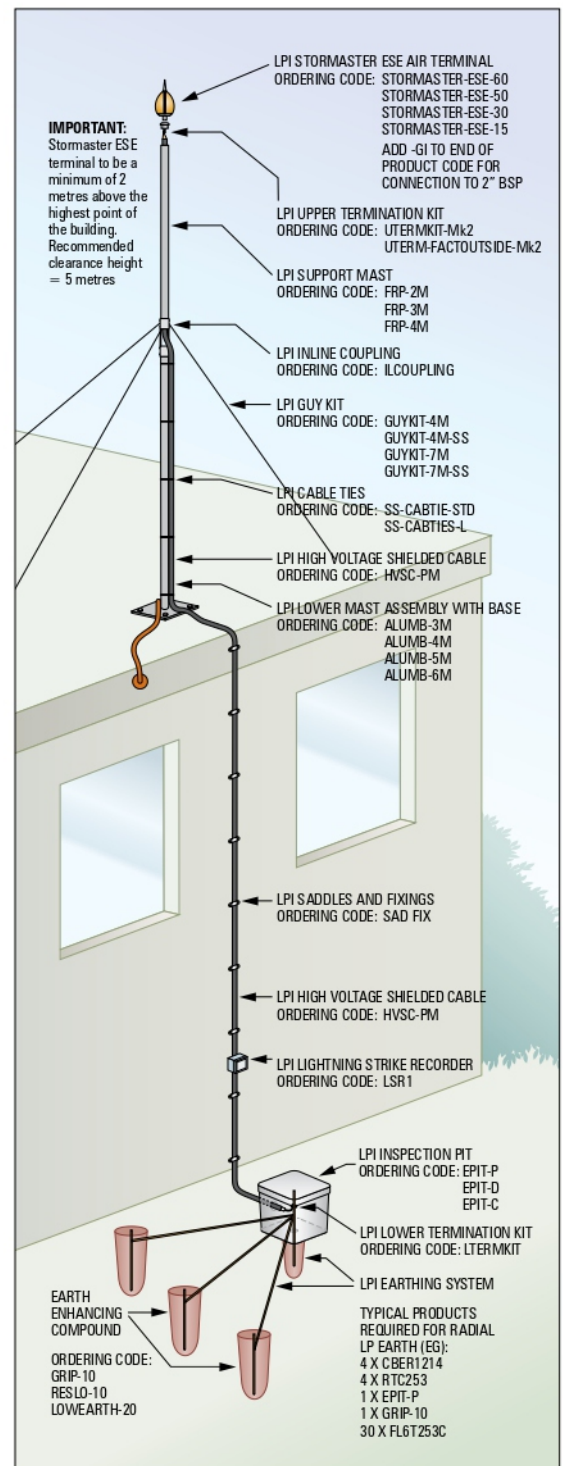

PROTECTION RADIUS, R_p (m)											
h = height of Stormaster ESE terminal above the area to be protected (m)	2	4	5	6	10	15	20	45	60	80	100
Protection Level I (Very High)											
Stormaster ESE 15	13	25	32	32	34	35	35	35	35	35	35
Stormaster ESE 30	19	38	48	48	49	50	50	50	50	50	50
Stormaster ESE 50	27	55	68	69	69	70	70	70	70	70	70
Stormaster ESE 60	31	63	79	79	79	80	80	80	80	80	80
Protection Level II (High)											
Stormaster ESE 15	15	30	37	38	40	42	44	44	44	44	44
Stormaster ESE 30	22	44	55	55	57	58	59	59	59	59	59
Stormaster ESE 50	30	61	76	76	77	79	79	79	79	79	79
Stormaster ESE 60	35	69	86	87	88	89	89	89	89	89	89
Protection Level III (Medium)											
Stormaster ESE 15	18	36	45	46	49	52	55	60	60	60	60
Stormaster ESE 30	25	51	63	64	66	69	71	75	75	75	75
Stormaster ESE 50	35	69	86	87	88	90	92	95	95	95	95
Stormaster ESE 60	39	78	97	97	99	101	102	105	105	105	105
Protection Level IV (Standard)											
Stormaster ESE 15	20	41	51	52	56	60	63	73	75	75	75
Stormaster ESE 30	29	57	71	72	75	78	81	89	90	90	90
Stormaster ESE 50	38	76	95	96	98	100	102	109	110	110	110
Stormaster ESE 60	43	85	107	107	109	111	113	119	120	120	120

Contact LPI for Protection Radius for Level I+ and Level I++

Disclaimer

- LPI maintains a policy of on-going product development, specifications are subject to change without notice.
- Application detail, illustrations and schematic drawings are representative only and should be used as guides.
- It should be noted that 100% protection level for direct strike lightning, lightning detection and surge and transient protection equipment is not possible and cannot be provided due to the lightning discharge process being a natural atmospheric event.

LPI STORMASTER ESE AIR TERMINAL

Advantages of the Stormaster ESE Terminal

A typical Stormaster ESE installation consists of a single Stormaster ESE terminal with an enhanced area of protection and downconductors connected to a dedicated earthing system designed to have a low impedance to lightning.

- LPI's Stormaster ESE system is simple to install and requires no special maintenance.
- LPI's Stormaster ESE system is a cost effective solution for providing your lightning protection whilst providing superior safety.
- The Stormaster ESE range of terminals have been fully tested in accordance with NF C 17-102 (2011) in a high voltage laboratory.

Research and Development

LPI has an ongoing commitment to Research and Development.

LPI personnel and its associates have been involved in a number of field trials throughout lightning prone regions of the world. This experience has extended throughout such countries as Australia, Indonesia, Sri Lanka the USA and South Korea.

NF C 17-102 (2011) The New Standard

NF C 17-102 is written specifically to ensure compliance with regard to the testing, application and installation of ESE terminals. The new standard, issued in 2011, is deemed to be applicable to structures of any height and for the protection of open areas. The previous version of the standard, first published in 1995, has been cancelled by the French standards organisation UTE and conformity with that version ceased in September 2012.

NF C 17-102 (2011) includes much more stringent requirements when compared to the 1995 version. The main differences are as follows:

1. There are now four protection levels rather than the previous three levels.
2. There are two new enhanced sub-levels for protection level I (levels I+ and I++).
3. Protection of structures taller than 60 metres is now allowed and there are special rules with regard to strike interception and downconductors. The top 20% of the building needs to be protected.
4. Some simple rules regarding downconductors, essentially two are needed, but one of them can be the natural components of the structure.
5. The earlier ban on coaxial insulated downconductors has been removed, but any use of insulated conductors has to follow the separation distance requirements per the IEC 62305 standards.



Ultimate direct strike lightning protection as installed across 65 countries around the world.

Distributed by:

WIJAYA LIGHTNING PROTECTION
Tools, Accesories, Lightning Protection, Grounding System,
Exothermic Welding, Electrical & Technical

WIJAYA
HP : 0812 1354 7353
HP : 0856 9253 4030
☎ : 0823 1205 5761

Workshop : Jl. Salemba Raya, Pasar Kenari Lama AL01 AKS 169,
Jakarta Pusat 10430
Telp/Fax : 021-3911912

Email : wjayakum@gmail.com / jayaaks169@gmail.com
www.wijayalightingprotection.com

LIGHTNING PROTECTION INTERNATIONAL PTY LTD

ABN 11 099 190 897



PO Box 379 Kingston, Tasmania, Australia 7051
49 Patriarch Drive, Huntingfield, Tasmania, Australia 7055

- Telephone: *Australia:* 03 6281 2477
International: +61 3 6281 2480
- Facsimile: +61 3 6229 1900
- Email: info@lpi.com.au
- Web: www.lpi.com.au